

HCCV PN 16



Hydraulically Controlled Check Valve Full Hydraulic Transient Control

Description

The A.R.I. Hydraulically Controlled Check Valve (HCCV) is a multipurpose damping device for pump discharge control. The valve functions as a one-directional Flow Control Valve, a Non-Return Valve and an internal Surge Anticipation Valve, all in one unit.

The hydraulically controlled check valve consists of two major parts:

1. A single shaft check valve.
2. A hydraulic control system.

The hydraulic control system is mounted on the check valve and installed at the pump station. The HCCV hydraulically controls the opening and closing of the check valve disc. The valve prevents slam subsequent to pump shut-down, reduces water hammer while switching the pump on and off and alleviates surges resulting from a power failure at the pump station.

Applications

- Pump Stations - at potable water, wastewater, desalination and industrial processing plants.

Operation

The HCCV consists of a self-contained unit operated both by the water flow generated by the main pump and by an electrically-powered hydraulic booster. The hydraulic control system manages the opening and closing phases of the check valve operation. The gradual opening phase is controlled at a predetermined rate. The angle and the timing of the two-stage closing phase can be adjusted to meet the flow regimen of the pipeline.

Main Features

- Innovatively designed to specifically control surge.
- The HCCV acts as an internal surge relief valve.
- Damping characteristics can be synchronized to match the dynamic behavior of the surge waves in the system and can be adapted to the transient conditions in the pipeline.
- Affords efficient pump station and pipeline protection.
- Hydraulically-opened full flow passage greatly reduces head losses and lowers energy costs.
- Controlled closing cycle remains fully functional, even during power failure.
- Opening cycle of the A.R.I. HCCV is set to prevent surge at pump start-up.
- Closing cycle of the A.R.I. HCCV is fully controlled and adjustable for the two principal phases:

1. Initial fast closing of the disk to 80% of its fully closed position – controllable from 2 to 10 seconds.

2. Secondary, damping stage, from 80% to fully closed – controllable from 5 to 200 seconds.

Supplemental fine-tuning by cam adjustments provides added flexibility of the operation.

- Timing adjustments can be easily made on-site.
- Smooth non-slam closure of the disc.
- Face to face dimensions according to ISO and EN standards.
- Metallic removable seals for easy servicing.
- Sealing seats are corrosion and wear resistant.
- Hydraulic accumulator provides the energy to close the disc in the event of a power failure.
- Low maintenance, long working life.

Specifications

- Nominal Size: 400 mm – 900 mm
- Pressure Rating: 6 bar, 10 bar, 16 bar.
- Max. Working Temp.: 70°C
- Electric Oil Pump: 3 Phase - 220 V, 5HP
- Electric Power Control: 24 DVC

Options

- Higher back-pressure application.
- Horizontal or Vertical Installation, upon request - for confined spaces.
- Special internal/external coatings for use with corrosive liquids.

Typical Power Failure Closing Characteristics

The first fast closing angle (%) and time (t_1) are continuously adjustable depending on the hydraulic characteristics of the line. The second damping closure is adjusted to include the surge wave return time: $2L/c$. This allows a part of the surge wave to be absorbed by the HCCV and pump resistance.

Example of three closing regimes

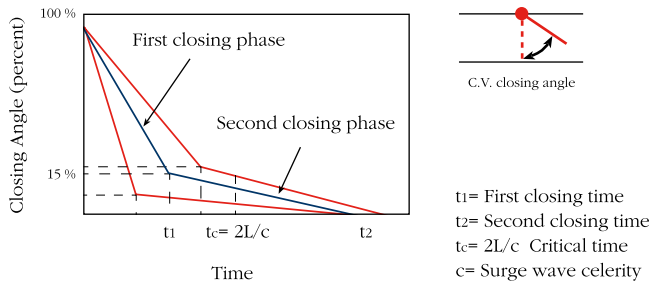

head down stream the HCC

head up stream the HCC

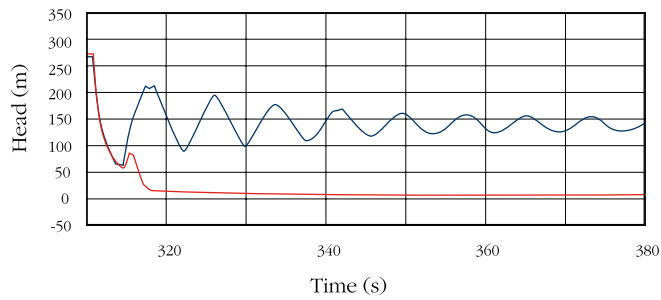

NR-040 HC PARTS LIST AND SPECIFICATION

No.	Part	Material
1.	Body	Ductile Iron ASTM A536 60-40-18
2.	Shaft	St. St. 17-4 PH
3.	Hydraulic Piston	
4.	Accumulator	
5.	Logic Block	
6.	Oil Tank	Steel
7.	Electric Motor	
8.	Operator Arm	Steel
9.	Limit Switch	
10.	Hydraulic Valve	
11.	Mechanical Interface	Ductile Iron ASTM A536 60-40-18

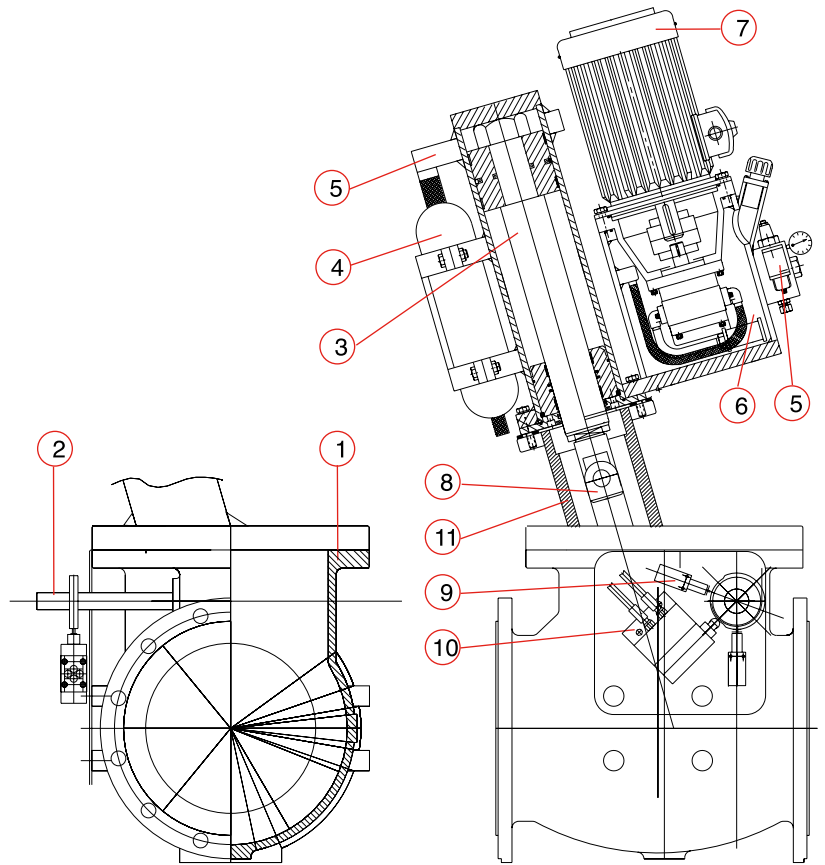

NR-050 HC PARTS LIST AND SPECIFICATION

No.	Part	Material
1.	Body	Ductile Iron A STM A536 60-40-18
2.	Shaft	St. St. SAE 431
3.	Hydraulic Piston	
4.	Accumulator	
5.	Logic Block	
6.	Oil Tank	Steel
7.	Electric Motor	
8.	Mechanical Interface	Ductile Iron ASTM A536 60-40-18
9.	Limit Switch	
10.	Hydraulic Valve	
11.	Counterweights	Steel
12.	Operator Arm	Steel
13.	Control Box	

